

Article history (leave this part):

Submission date: 2024-07-07

Acceptance date: 2024-12-15

Available online: 2024-12-28

Keywords:

Change; organizational change management; strategic leadership; learning; learning organization

Funding:

This research received no specific grant from any funding agency in the public, commercial, or not-for-profit sectors.

Competing interest:

The author(s) have declared that no competing interests exist.

Cite as (leave this part):

sami, rasha. (2023). Title. Journal of Science and Knowledge Horizons, 3(02), 213-235.

<https://doi.org/10.34118/jskp.v3i02.3400>

The authors (2024). This Open Access article is licensed under a Creative Commons Attribution-NonCommercial 4.0 International License (CC BY-NC 4.0) (<http://creativecommons.org/licenses/by-nc/4.0/>). Non-commercial reuse, distribution, and reproduction are permitted with proper citation

Journal of Science and Knowledge Horizons
ISSN 2800-1273-EISSN 2830-8379**Organizational Change Management as a Mechanism for Developing Learning Organizations under the Mediating Role of Strategic Leadership: A field study at HODNA LAIT, a dairy production company****Boudjellal Abderrahim**^{*1}**Bareq Habeeb Sadiq**²¹ University of Msila (Algeria), boudjellal.abderrahim@univ-msila.dz, <https://orcid.org/0000-0003-2414-9718>² University of Baghdad (Iraq), Bariq.h@cois.uobaghdad.edu.iq, <https://orcid.org/0009-0008-9810-3505>**Abstract:**

This study aims to explore the role of organizational change management in adopting the learning organization model, considering the presence of supportive strategic leadership as a mediating variable. The study population comprised 380 employees at HODNA LAIT, a dairy and dairy products manufacturing company in Algeria. The researchers employed a descriptive-analytic approach, relying on a questionnaire as the primary data collection instrument. Initially, 300 questionnaires were distributed, of which 226 were retrieved, forming the study sample. Statistical analysis of the data was conducted using AMOS.v24. The study revealed several significant findings, including a direct and significant influence between organizational change management and the learning organization, and the mediating role of strategic leadership in this relationship.

*** Boudjellal Abderrahim**

1. Introduction

Modern business organizations face a constantly evolving and changing external environment. This environment is characterized by uncertainty and unpredictability, making it challenging for organizations to effectively adapt and navigate these changes while pursuing their strategic goals. Therefore, organizations are compelled to embrace change and adopt modern approaches to effectively manage and control these changes and their outcomes. This requires a strong foundation built on rational reasoning and strategic leadership capable of anticipating future changes and developing appropriate strategies to address them.

For change to be effective, organizations must adopt a detailed action plan from the very beginning. This plan should focus on their current state and outline a path toward a better future. This requires them to step outside of their familiar frameworks of work and thought, analyzing all the elements that will create the desired change.¹

1.1 Problem Statement

In the modern era, the rapid and interconnected changes in the global environment have made it imperative for organizations to develop their resilience and adaptability. The traditional organizational model, characterized by rigidity, inflexibility, and multiple layers of management, has become unsuitable for dealing with the current environment, which is marked by constant volatility and uncertainty. This has led to the necessity of change and a shift toward a more flexible and effective model known as: the learning organization.² The success of a change process is linked to the extent to which the manager is convinced of the benefits and outcomes of the change process, and their ability to manage it. Dealing with change situations negatively can have dire consequences for individuals and organizations, leading to resistance to change. Therefore, organizations should take into account the need to deal with change through in-depth studies to choose the best methods, develop an effective strategy, and get individuals to embrace it positively. This requires them to transform into a learning organization that adapts to a turbulent and rapidly changing environment.³

Because change management cannot be successful without the support of strategic leadership that allows organizations to leverage their intelligence and ingenuity, this study aims to determine the role of organizational change management in adopting the learning organization model under supportive strategic leadership. The study seeks to answer the following question:

- **Does the implementation of organizational change management have an impact on the adoption of the learning organization model in the presence of supportive strategic leadership within the studied organization?**

To address all aspects of the main research question, the following sub-questions can be asked:

- Does organizational change management have a direct and statistically significant impact on strategic leadership in the studied organization ?
- Does organizational change management have a direct and statistically significant impact on the adoption of the learning organization model in the studied organization?
- Does strategic leadership have a direct and statistically significant impact on the adoption of the learning organization model in the studied organization?
- Does strategic leadership mediate the relationship between organizational change management and the learning organization in the studied organization?

1.2 Research Hypotheses:

To answer the main question and its sub-questions, the following hypotheses were formulated:

H₁: Organizational change management has a significant impact on strategic leadership in the studied organization.

H₂: Organizational change management has a significant impact on the adoption of the learning organization model in the studied organization.

H₃: Strategic leadership has a significant impact on the adoption of the learning organization model in the studied organization.

H₄: Strategic leadership mediates the relationship between organizational change management and the learning organization in the studied organization.

3.1 Research Objectives:

- To present the key concepts and scientific foundations of organizational change management, the learning organization, and strategic leadership.
- To identify the levels of implementation of organizational change management, the learning organization, and strategic leadership in the studied organization.

- To clarify the impact relationship between organizational change management and the learning organization in the studied organizations.
- To propose recommendations for decision-makers, drawing upon the findings of the applied study.

1.4 Study methodology:

This study employed a descriptive approach, which is suitable for this type of study. Based on the principles of this approach, the phenomenon under study was described theoretically through relevant books and studies. For the field component, data was collected and analyzed in the field of study using a questionnaire designed for this purpose.

1.5 Previous Studies:

Study (Pascal, 2006): Organizational Change: What Training Support?

This study aimed to highlight the relationship between training policy and organizational change within institutions. It explores the types of training appropriate for optimizing organizational change processes adopted by organizations. The study also emphasizes the importance of accompanying organizational change processes with training and education as a prerequisite for success. Through field interviews with officials of a public facility, the researcher focused on a municipality in the city of Rouen, France. The research found that this administration faces critical situations that require a review of many of its policies in managing its human resources, particularly its organizational structure, including the organizational form, the system of grants and bonuses, the description of jobs and positions, and the annual performance evaluation of employees.

Study (Uzma R. K, 2016): The Role of Leadership in Organizational Change

This study aimed to understand the role of leadership in organizational change by exploring the relationship between successful organizational change and leadership through an innovative approach. The study investigated the role of leadership in successful organizational change and identified the patterns and qualities that should be adopted for the effectiveness of the organizational change process. The researcher used a descriptive approach and concluded that making changes without a clear vision and new ideas can lead to a lower level of success. The leader's vision is crucial to achieving a high level of success in implementing organizational change.

Study (Lakhdar, 2019): The Readiness of the Learning Organization to Adopt Organizational Change Strategies - A Case Study of the Tax Directorate

This research aims to highlight the impact of the learning organization in adopting organizational change strategies within the Tax Directorate of Jilfa Province. The study population consisted of 90 employees. The researcher employed a descriptive analytical approach, distributed a questionnaire to a simple random sample of 30 employees. The findings indicated a statistically significant impact of the learning organization on the adoption of organizational change strategies within the studied institution.

1.6 Research Gap:

Most previous studies have addressed organizational change management from different perspectives (areas of organizational change, methods of organizational change management...), while the current study focused on organizational change management as an administrative approach that works to move the organization from its current state to a more efficient and effective future state in the presence of strategic leadership supporting this change.

1.7 Study model

Figure 01 : Theoretical Study Model

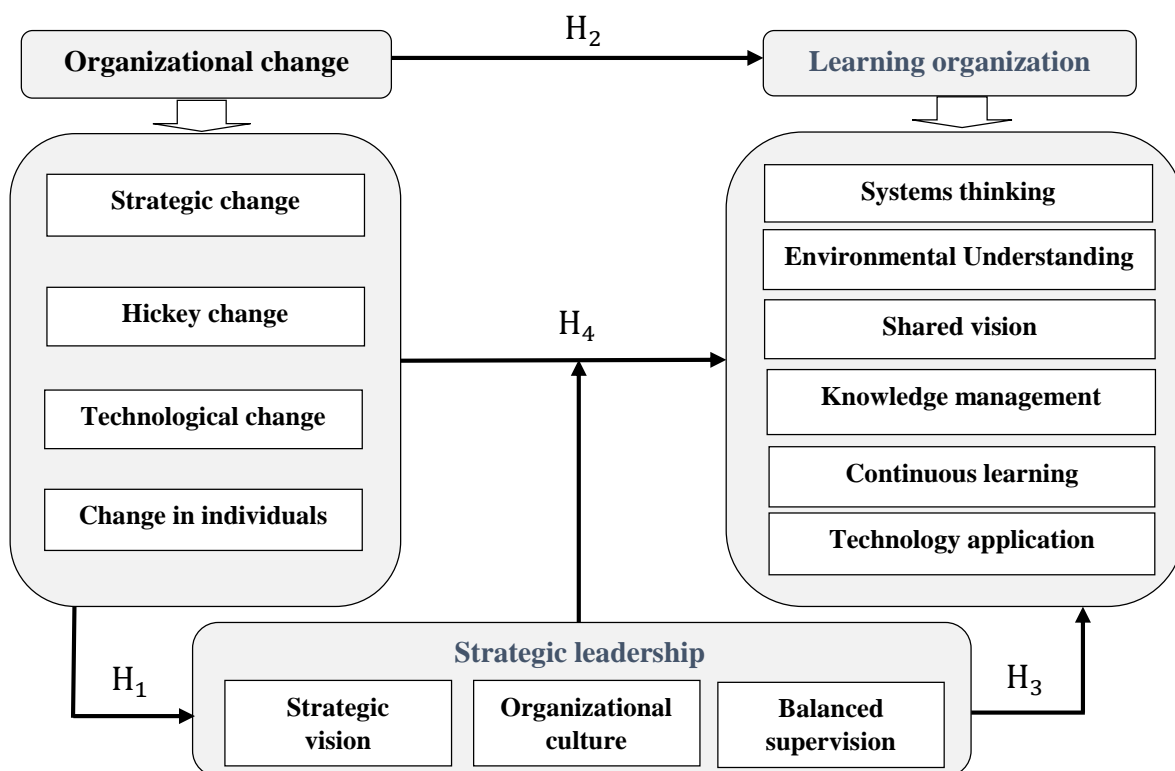

Source : Prepared by the researchers

2. Theoretical Framework of the Study

2.1 Organizational Change Management

Change, in its general sense, is the shift from the current equilibrium point to the targeted equilibrium point. It is also viewed as a dynamic movement by following novel methods and approaches resulting from material and intellectual innovations due to material intellectual progress.⁴

(Thomas 2014) defined change management as the effective management of business change, such that executives, managers and front-line workers work collaboratively to successfully implement required process, technology, or organizational changes.⁵ (Paton, 2008) sees it as the organized use of knowledge, tools, and resources related to change that ensures the organization's ability to achieve business strategies.⁶

2.1.1 Dimensions of Organizational Change

The following table shows the most important dimensions dealt with by some researchers:

Table 01: "Dimensions of Organizational Change Management "

Study And the Sunnah	Dimensions of organizational change						
	Change in leadership	Service change	Practical change	Technological change	Structural change	Change in individuals	Strategic change
(Saeeda, 2018)					*	*	
(Al-Hajri, 2017)					*		
(Bushua, 2019)			*	*			
(Obaid, 2009)				*	*	*	
(YUP, 2019)				*	*	*	*
(Salama, 2016)		*			*		
(Bouterfa S, 2010)	*			*	*	*	*
(Bug, 2018)					*	*	
(Dosa, 2008)					*	*	*
(Yunus, 2017)				*	*	*	*
total	1	1	1	5	6	7	4

Source: Prepared by the researchers based on previous studies

The table reveals that a majority of researchers agree on four dimensions of organizational change: strategic change, structural change, technological change, and individual-level change.

2.2 The Learning Organization

Peter Senge defined a learning organization as an organization where people continually expand their capacity to create the results they truly desire.⁷ is also defined as: An organization that has developed the capacity for continuous adaptation and change because all its members are actively engaged in identifying and resolving issues related to work.⁸ Therefore, the learning organization is based on three core pillars: a conducive environment, supportive leadership, and continuous learning.

2.2.1 Dimensions of the Learning Organization

The following table illustrates the key dimensions discussed by various researchers:

Table 02: Dimensions of the Learning Organization

Study And the Sunnah	Dimensions of the learning organization							
	Shared vision	Empowerment	Technology application	Personal control	knowledge management	Systems thinker	Understanding environment	Continuous learning
(Al-Zu'bi, 2017)							*	*
(Pharaoh, 2015)				*	*	*	*	
(Sahla, 2016)	*			*		*		*
(Qarmiti, 2020)	*	*				*		*
(Fathi, 2018)			*		*			*
(Abbas, 2020)	*						*	*
(Lakhdar, 2019)	*					*		*
(Al-Alusi, 2017)			*		*			*
(Mahmod, 2018)		*	*		*		*	*
the total	5	2	3	2	4	4	4	7

Source: Prepared by the researchers based on previous studies

The table highlights that most studies have focused on these dimensions: organizational thinking, understanding the environment, shared vision, knowledge management, continuous learning, and technology application.

2.3 Strategic Leadership

Strategic leadership is defined as the ability to articulate the organization's strategic vision, as well as to motivate and encourage others to believe in it and understand it.⁹ (Normy R, 2018) argue that strategic leadership lies in the leader's ability to predict, maintain flexibility, and empower others to create strategic change as needed. This facilitates the organization's ability to adapt to rapid environmental changes.¹⁰

Strategic leadership provides solutions to multiple functions within the organization, seeking to understand and align the internal environment with the external environment. It recognizes that different situations require different types of intelligence to implement flexibility and adapt to the required course of action.¹¹

2.3.1 practices of Strategic Leadership

The key practices of strategic leadership can be illustrated in the following table based on previous research by academics:

Table 03: practices of Strategic Leadership

Study And the Sunnah	Dimensions of strategic leadership									
	Organizational learning	Core adantage	modern techniques	Empowering employees	Organizational change	Balanced supervision	Ethical practices	Organizational culture	Human capital	Strategic vision
(Al-Sarraj, 2017)						*	*	*	*	*
(Jassem, 2011)		*	*					*	*	*
(Fourie, 2009)							*	*		*
(Qarmash, 2020)					*	*				*
(Nthini, 2013)				*		*	*	*		*
(Muzee, 2016)	*				*				*	
(Faisal, 2017)	*		*	*						
(Hebal, 2018)						*		*	*	*
the total	2	1	2	2	2	4	3	5	4	6

Source: Prepared by the researchers based on previous studies

Given the diverse and varied studies on the practices of strategic leadership, we have chosen three key dimensions based on their significance and suitability for our research model. These dimensions are: defining a future vision, fostering a supportive organizational culture, and balanced organizational control.

3. Framework of the Study:

3.1 Field Study Procedures:

3.1.1 Study Population and Sample: The study was conducted on the industrial sector in Algeria, specifically at HODNA LAIT, a company specializing in the production and marketing of milk and dairy products. The study population comprised all employees of the company, totaling 380 individuals. The minimum sample size for the study was calculated using the Steven K. Thompson formula:

$$n = \frac{N * P(1-P)}{[N-1 * (d^2/Z^2) + P(1-P)]}$$

After calculation, the minimum sample size for the study population at a 95% confidence level was found to be approximately $195 \leq n$. Subsequently, a simple random sample of 300 individuals was selected from a population of 380. The study instrument was distributed among these participants, with 231 questionnaires retrieved and 5 discarded, leaving 226 questionnaires representing the study sample at HODNA LAIT.

The demographic variables included gender, educational qualifications, and years of experience. The following table shows the characteristics of the study sample.

Table 01: Characteristics of the Study Sample

Variable	Groups	Repetition	ratio %
Sex	Males	161	71.2
	Females	65	28.8
Qualification	Bachelor's degree or less	78	34.5
	Bachelor's degree	86	38.05
	Engineering or Master's degree	51	22.56
	Postgraduate	11	04.01
Years of Experience	Less than 5 years	87	38.49
	From 5 to 9 years	68	30.08
	From 10 to 15 years	40	17.69
	Older than 15 years	31	13.71

Source: Prepared by researchers based on SPSS 26 outputs

3.1.2 Study Boundaries:

- **Temporal Boundaries:** The study was conducted during the months of April, May, and June of 2024.
- **Spatial Boundaries:** The study took place at the HODNA LAIT institution in Algeria.

- **Thematic Boundaries:** The study focused on the role of organizational change management in developing learning organizations within the context of supportive strategic leadership.

3.1.3 Statistical Analysis Methods

The statistical analysis of the data included the following methods:

- Confirmatory Factor Analysis (CFA): Used to test the construct validity of the proposed model.
- McDonald's Omega: Employed to assess reliability.
- Path Analysis: Utilized to test the study's hypotheses.

3.1.4 Study Instruments: A questionnaire served as the primary data collection instrument. Its design is illustrated in Table 2.

Table 2: Study Instrument Design and Variable Coding

	Latent variables	Coding	Observed variables	N°
Organizational change management (OCM)	Strategic change	SC	SC1 – SC4	4
	Structural change	SLC	SLC1 – SLC5	5
	Technological change	TC	TC1 – TC4	4
	Change in individuals	CI	CI1 – CI4	4
Strategic leadership (SL)	Future vision	FV	FV1 – FV5	5
	Organizational culture	OC	OC 1 – OC 4	4
	Balanced supervision	BRO	BRO 1 – BRO 4	4
learning organization (LO)	Systems thinking	ST	ST1 – ST5	5
	Understanding the environment	UE	UE1 – UE5	5
	Shared vision	CV	CV1 – CV5	5
	knowledge management	KM	KM1 – KM5	5
	Continuous learning	CL	CL1 – CL5	5
	Technology application	TA	TA1 – TA5	5

Source: Prepared by researchers

3.2 Assumptions of Confirmatory Factor Analysis

3.2.1 Face Validity of the Study Instrument

was displayed the questionnaire's items and axes to experts and a panel of referees, including management professors specializing in administration and the learning organization, to assess its suitability as a data collection tool.

3.2.2 Test of the instrument's reliability

To verify the instrument's ability to measure the dimensions and ensure its validity, we employed McDonald's Omega coefficient using the AMOS v24

software. Omega values (ω) exceeding 0.70 indicate internal consistency in the study instrument.

Table 03: Results of McDonald's Omega Coefficient

Variable	Dimension	Ferries	%" ω "	Variable	Dimension	Ferries	%" ω "
OCM	SC	4	83.2	LO	ST	5	79.1
	SLC	5	85.4		UE	5	75.3
	TC	4	78.8		CV	5	77.7
	CI	4	81.3		KM	5	80.2
	FV	5	76.8		CL	5	86.3
SL	79.1	4	TA				
	84.7	4	84.7				

Source: Prepared by researchers through MACRO-OMEGA outputs

The table results indicate that all "McDonald's Omega" values used in the study were above the minimum threshold of 70% across all questionnaire dimensions. This suggests a high level of reliability for the study instrument

3.2.3 Multivariable Normal Distribution of Data:

H₀: The data follows a normal distribution.

H₁: The data does not follow a normal distribution.

Table 04: Results of Mardia's Coefficient.

	N° of variables	Multivariate	c.r
OCM	4	3.581	.451
SL	3	-1.124	-1.022
LO	6	1.451	0.981

Source: Prepared by researchers based on AMOS.V24 output

Observing the critical values of Mardia's coefficient (c.r) to be less than (± 1.96), we accept the null hypothesis H₀, which posits normality of the data distribution, and reject the alternative hypothesis H₁.

3.3 Confirmatory Factor Analysis (CFA) of Study Variables:

Confirmatory Factor Analysis (CFA) involves both testing the construct validity and evaluating the fit of the measurement model through fit indices.

3.3.1 Evaluating the Organizational Change Management Model:

Figure 02: Standard model for organizational change management

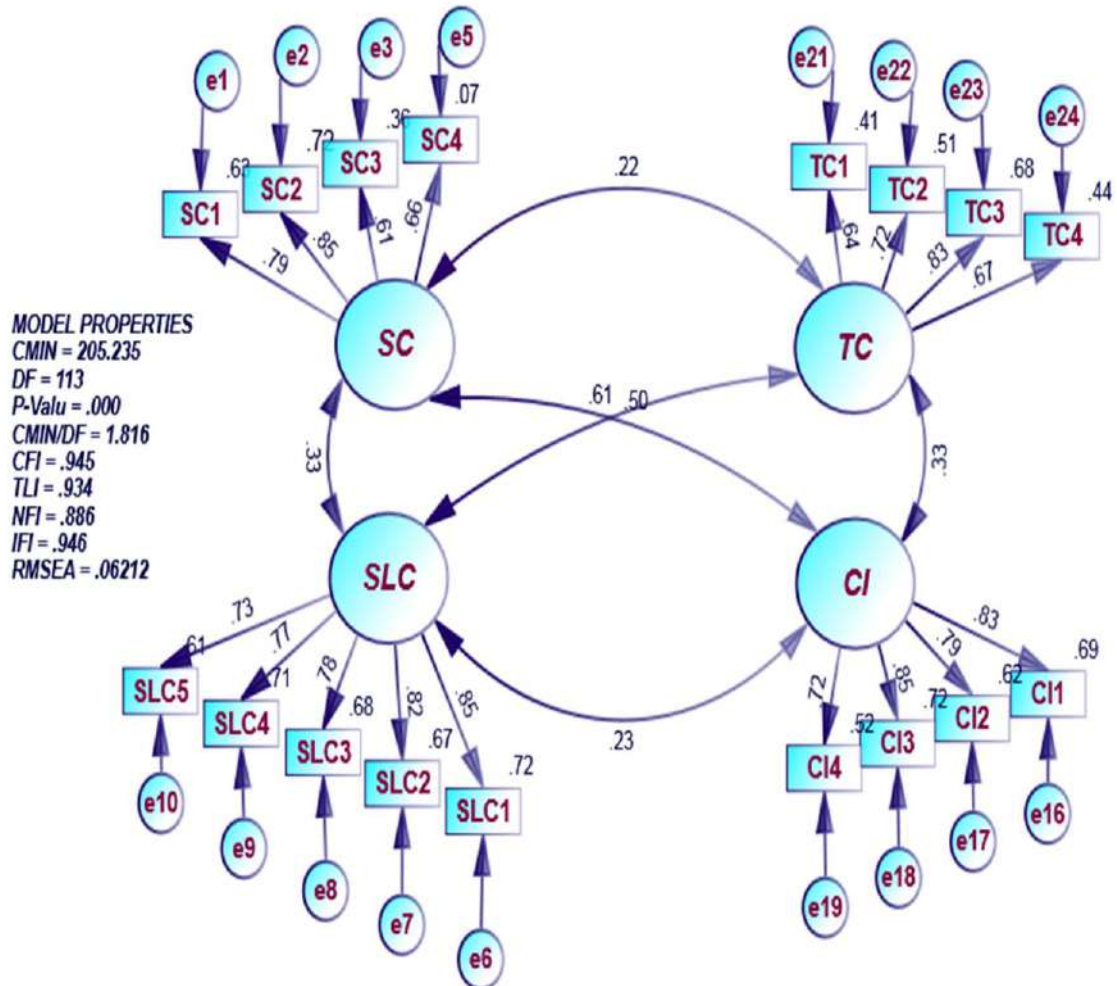

Source: Prepared by researchers based on AMOS.V24 output

dimensions of the independent variable (organizational change management) are between 0.61 and 0.85, thus it is statistically significant, being greater than 60%. All values of the composite reliability (CR) are greater than 1.96 which confirms the construct validity of the proposed model.

To evaluate the model's fit to the collected data, the goodness-of-fit indicators shown in Table 05 were used.

Table 05: Evaluation of Goodness-of-Fit Indicators

Indicator	abbreviation	Admission field	Model results	decision
Standard chi-square	CMIN/DF	$0 < \text{CMIN/DF} < 2$	1.816	good
Comparative conformity index	CFI	$0.90 < \text{CFI} < 0.97$	0.945	good
Tucker-Lewis index	TLI	$0.90 < \text{TLI} < 0.95$	0.934	good
Standard conformity index	NFI	$0.80 < \text{NFI} < 0.90$	0.886	acceptable
Increased conformity index	IFI	$0.80 < \text{IFI} < 0.90$	0.946	good
The square root of the approach error	RMSEA	$0.05 < \text{RMSEA} < 0.08$	0.062	good

Source: Prepared by researchers based on AMOS.V24 output

Table 05 presents a summary of the evaluation of key goodness-of-fit indices used by the researchers. The standardized Chi-Square value (CMIN/df = 1.816) falls within the acceptable range of [2; 0], indicating a statistically significant model fit. Furthermore, all other goodness-of-fit indices exhibit acceptable values. This suggests that the organizational change management model is highly suitable for hypothesis testing.

3.3.2 Assessment of the strategic leadership model

Figure 03: Standard Model of Strategic Leadership

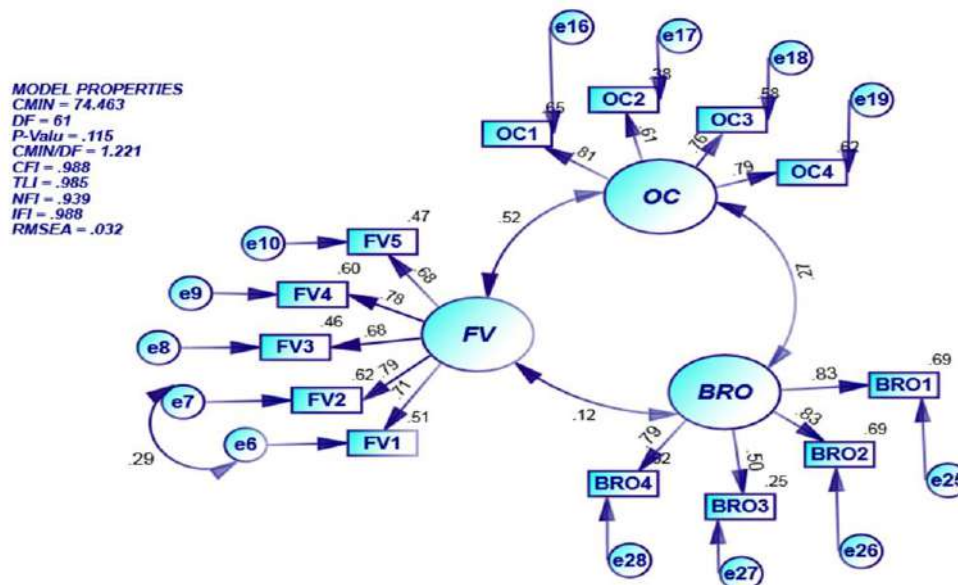

Source: Prepared by researchers based on AMOS.V24 output

From Figure 03 above, we observe that most of the saturation values loaded on the dimensions of the mediating variable (strategic leadership) are statistically significant (greater than 0.6), and all C.R. values are no less than 1.96. This indicates that the items are capable of explaining the dimensions loaded on them, Therefore, the construct validity of the strategic leadership model is achieved.

The figure also provides a summary of the most important indicators of good fit. Comparing these indicators with the normative values shown in Table 05, we can confirm the good fit of the model to the data provided, as the ratios of all indicators fall within their acceptable range.

3.3.3 Evaluating the learning organization model:

Figure 04: The learning organization standard model

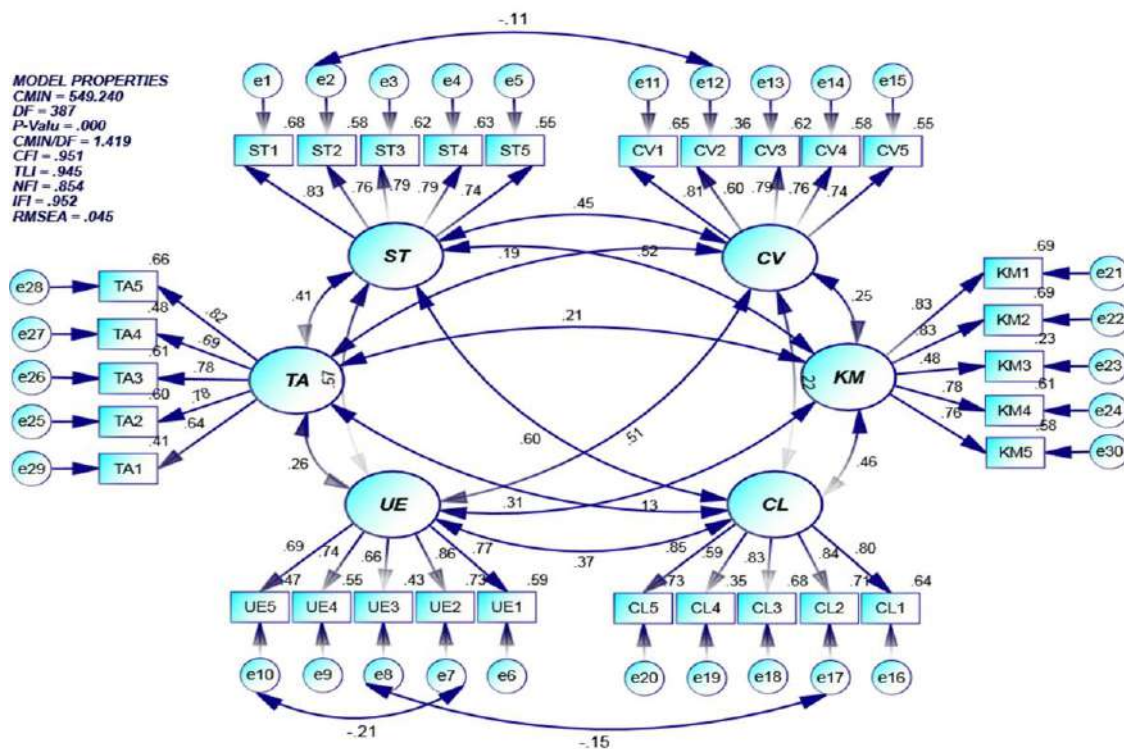

Source: Prepared by researchers based on AMOS.V24 output

Examining the saturation values loaded on the dimensions of the dependent variable as depicted in Figure 4, we observe that they are significant within their acceptable range (above 0.6). Additionally, all C.R. values surpass the standard value of 1.96, reinforcing the construct validity of the learning organization model. Furthermore, the values of goodness-of-fit indices shown in the same figure suggest a good fit for the proposed model, aligning with their respective acceptable ranges.

3.4 Hypothesis Testing and Results Interpretation

Path analysis was employed to examine both the direct and indirect effects of multiple independent variables on several dependent variables simultaneously. This analysis incorporated the mediating role of an intervening variable and was conducted using AMOS v24.

3.4.1 Testing the direct impact between organizational change management and both strategic leadership and the learning organization

Figure 05 : Path analysis of organizational change management dimensions

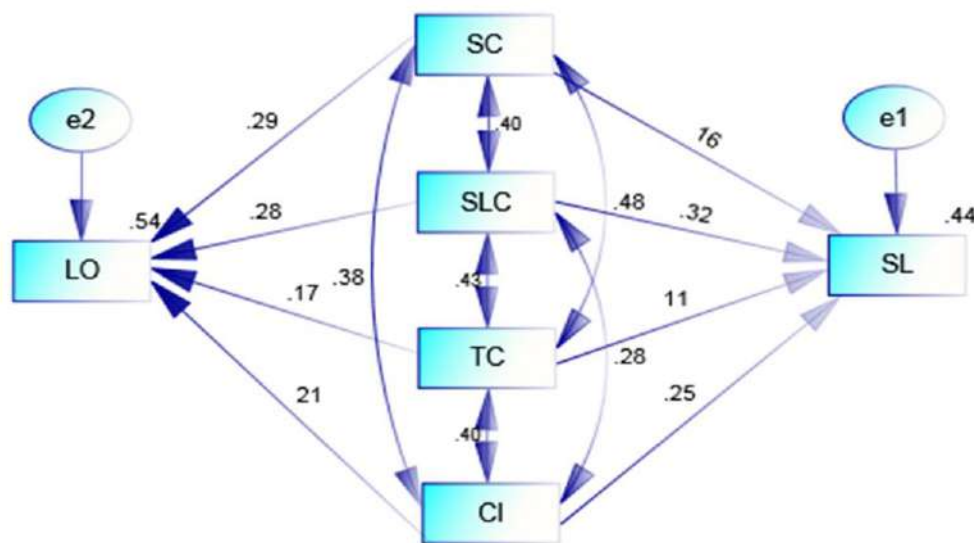

Source: Prepared by researchers based on AMOS.V24 output

Figure 05 illustrates the direct impact paths of the independent variable dimensions (OCM) on the mediating variable (SL) and the dependent variable (LO) simultaneously. Regression coefficient values ranging from 0.11 to 0.32 indicate a positive effect between the variables. To determine the statistical significance of this impact and its interpretability, we rely on the values recorded in tables 06 and 07.

Table 06: Path analysis results for leadership dimensions.

Variable	Estimate	S.E.	C.R.	P	R Square
SL <---- SC	.324	.065	2.415	.000	.523
SL <---- SLC	.146	.058	.311	.068	
SL <---- TC	.214	.052	2.501	.002	
SL <---- CI	.163	.061	3.171	.041	

Source: Prepared by researchers based on AMOS.V24 output

The results shown in the table above highlight a significant impact between each of (strategic change, technological change, individual change) and strategic leadership SL at statistically significant levels (< 5%), with acceptable regression coefficients (0.324, 0.214, 0.163) respectively. However, after structural change (SLC) appears statistically insignificant with a significance level of 0.068. Overall, the R² value indicates that the dimensions of change management together can explain 52.3% of the changes occurring in strategic leadership.

Table 07: Path Analysis Results of Change Management Dimensions and the Learning Organization

Variable	β Estimate	S.E.	C.R.	P	R Square
OL <----- SC	.153	.050	1.254	.020	.561
OL <----- SLC	.451	.063	.020	.000	
OL <----- TC	.512	.057	.451	.000	
OL <----- CI	.224	.051	1.017	.011	

Source: Prepared by researchers based on AMOS.V24 output

The results presented in Table 07 demonstrate a significant relationship between all dimensions of organizational change management and the learning organization, with a significance level of 0.05. The regression coefficients are acceptable (0.153, 0.451, 0.512, 0.224) respectively. The R-squared value indicates that the dimensions of change management collectively explain 56.1% of the variance in the dependent variable (learning organization). The remaining variance is attributed to factors outside the scope of the study.

3.4.2 Testing the direct impact between strategic leadership and the learning organization

Figure 06: Multiple regression between strategic leadership and the learning organization

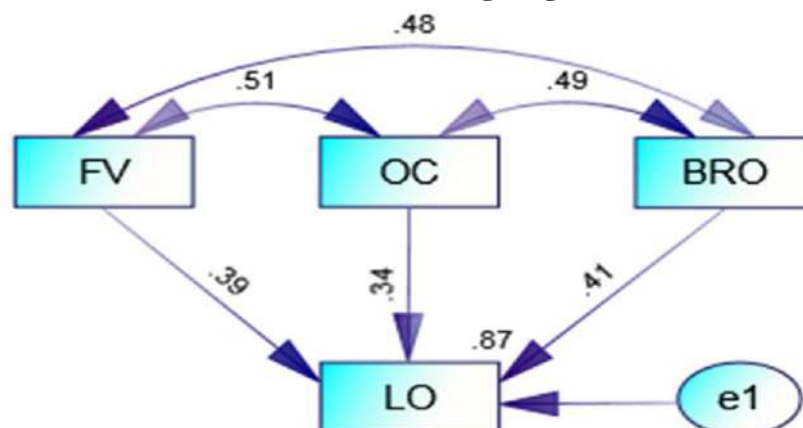

Source: Prepared by researchers based on AMOS.V24 output

Table 08: Standardized estimates of the dimensions of strategic leadership and the learning organization

Variable	Estimate	S.E	C.R	P	R Square
LO <----- FV	.295	.023	12.789	***	.625
LO <---- OC	.294	.026	13.720	***	
LO <--- BRO	.325	.024	11.203	***	

*** P > .001 , ** P > .01 , * P > .05

Source: Prepared by researchers based on AMOS.V24 output

The standardized regression coefficients shown in Figure 06, and the results listed in Table 08, reveal a positive effect relationship between the variables. The standardized regression coefficients for the variables range from 0.34 to 0.41, indicating positive and statistically significant values. As observed from the table, the t-statistic value for all dimensions of strategic leadership is greater than the critical value of 1.964, with a significance level less than 1%. This leads us to reject the null hypothesis (H0) and accept the alternative hypothesis (H1), which posits a significant direct impact of all dimensions of strategic leadership on the learning organization. Overall, the determination coefficient value of 0.625 suggests that all dimensions explain 62.5% of the variations in the learning organization model.

3.4.3 Mediation Hypothesis Test

We will use the "Baron & Kenny" approach to test the contribution of strategic leadership in supporting the relationship between organizational change management and the learning organization, as illustrated in Figure 07.

Figure 07: Path analysis on the mediating variable

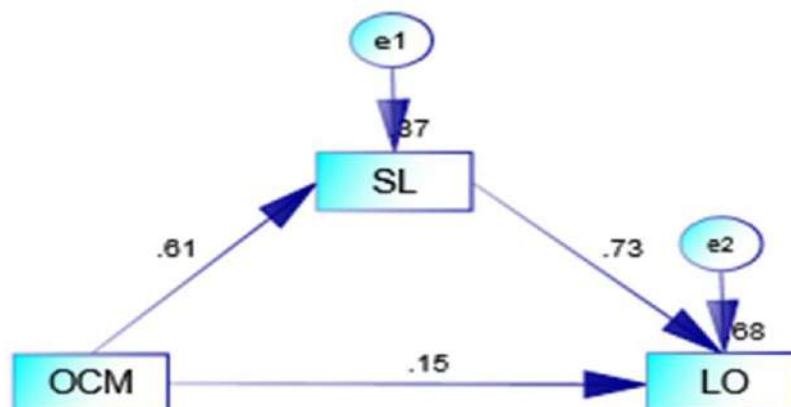

Source: Prepared by researchers based on AMOS.V24 output

The standardized regression coefficient values shown in the model above indicate positive impact relationships between the study variables (0.61, 0.73, 0.15). The values above the rectangles represent the explanatory power of the influencing variable on the influenced variable and are considered high as they exceed 60%. To determine the statistical significance of these results, we refer to Table 09.

Table 9: Path analysis estimates for study variables

Variable	Estimate	S.E.	C.R.	P
SL <---- OCM	.606	.054	11.165	***
LO <----- OCM	.151	.049	3.104	.002
LO <----- SL	.726	.049	14.830	***

Source: Prepared by researchers based on AMOS.V24 output

Table 9 summarizes the regression coefficient values (β), standard errors (E.S), and critical t-values (C.R). The regression coefficients for the three paths were 0.370, 0.227, and 0.507 respectively, demonstrating statistical significance ($p < 1\%$). Moreover, the C.R values exceeded the threshold of 1.964, confirming the fulfillment of all three conditions stipulated by Baron & Kenny.

To investigate the mediating effect of the intervening variable (strategic leadership), the following table:

Table 10: Direct, indirect and total impact of the study variables

Path	Dir Effects	Indr effects	Tot effects	Conclusion
LO <---OL <--- SD	.443**	.152**	0.595**	Partial Mediation
P-Valu	0.002	0.003	0.005	
Ind Effects = $0.370 * 0.507$				
Tot Effects = Dir Effect + Ind Effect = $0.227 + 0.188$				

Source: Prepared by researchers based on AMOS.V24 output

Table 10 highlights the significant overall effect of Organizational Change Management (OCM) on the Learning Organization (LO) in the absence of the mediating variable (SL) at a significance level of 0.005. The direct effect remains significant at 0.002. Notably, the indirect effect is also significant at 0.003, although it is less pronounced than the direct effect ($0.443 > 0.152$) and the overall effect ($0.595 > 0.152$). This suggests that strategic leadership partially mediates the relationship between change management and the learning organization.

4. The final model of the study:

After testing the study hypotheses and interpreting the results, a final model was developed that highlights the actual relationships between the study variables. This is illustrated in the following figure:

Figure 08 : Experimental study model

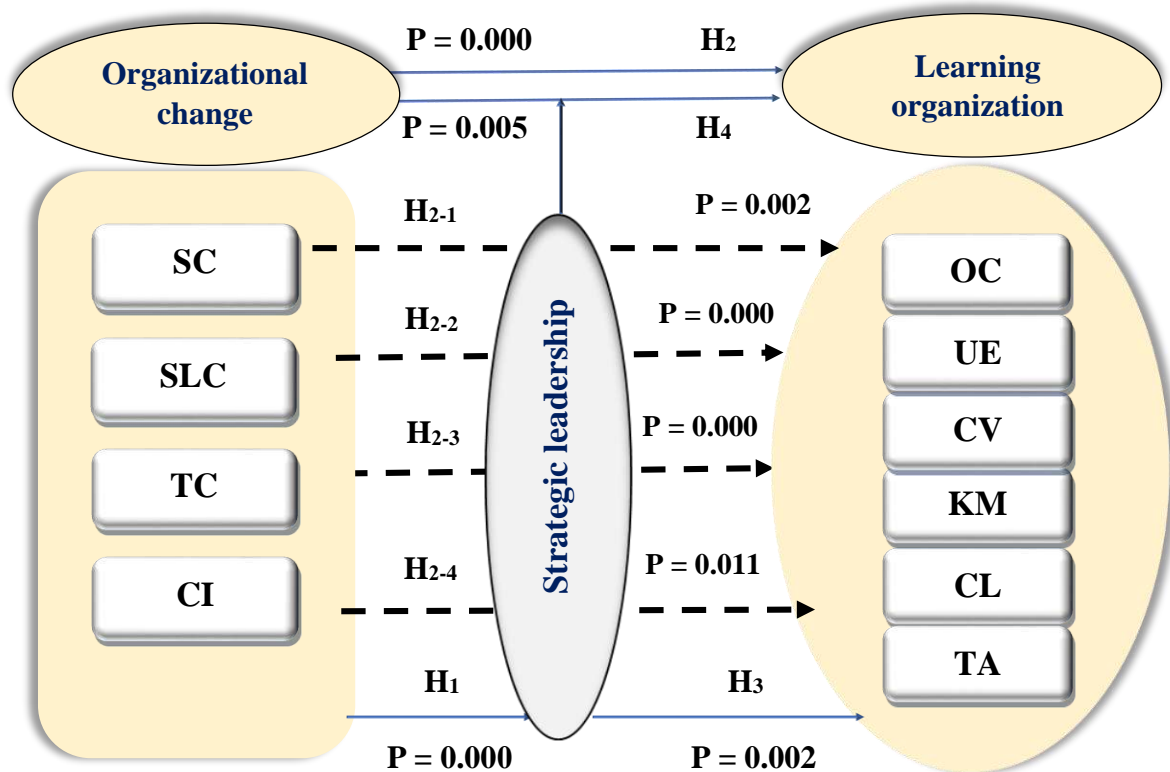

Source: Prepared by researchers based on the results of the study

5. Conclusion:

This study, in its theoretical aspect, has focused on a series of theoretical foundations underlying organizational change management, strategic leadership, and organizational learning. It has highlighted the importance of the change process in business organizations, considering it a safety valve in critical and challenging situations faced by these organizations. This is achieved through its ability to accurately envision the organization's mission and future strategies, aligning them with the continuous changes in the external environment. This also includes continuous changes in organizational structures, development of human resources, and equipping them with skills that encourage innovation and empower

them to make appropriate decisions. The success of these practices has a positive impact on the organization's performance in carrying out its tasks, on the one hand, and increases its productivity and development on the other. The study also emphasized the importance of strategic leadership as a crucial strategic necessity for driving change and ensuring the organization's development and survival. It plays a decisive role in managing change and adapting to internal and external environmental conditions by strategizing, building a strategic vision, and developing an organizational culture that promotes learning within the organization. It also involves implementing balanced control methods to identify and correct errors, aiming to achieve maximum success in the future.

5.1 Practical Results

- The study's results revealed a direct, positive, and statistically significant impact of organizational change management on the development of learning organizations within the studied institution. This explains that the owners and leaders of HODNA LAIT are fully aware of the importance of organizational change management in supporting learning and development within the organization. They are working to identify errors before they occur and to implement radical changes to avoid those errors (strategic change). They also focus on constantly updating structures and material resources (strategic change), aiming to develop individuals' individual and collective skills, and most importantly, encouraging them to continue learning and training through material and moral incentives, developing programs and workshops specifically to raise awareness about the need for change, which contributes to strengthening their job satisfaction and increasing their loyalty to the organization (individual-level change).

- The results showed that strategic leadership partially mediates the relationship between organizational change management and the development of learning organizations. This is attributed to the great attention the leadership of the studied institution pays to its strategic directions, values, systems, and instructions related to its internal culture. This plays a significant role in creating a conducive organizational climate for work, innovation, and introducing new ideas. During the field visits and interviews with some executives, the researcher observed that HODNA LAIT has strategic leadership that provides individuals with a sense of support and ease in performing their tasks, on the one hand, and encourages them to take responsibility and maintain their jobs, on the other hand. These elements are closely linked to individuals' job stability and their desire to develop their skills and improve their institution.

- The study's results indicated a significant positive impact of strategic leadership on the development of learning organizations. This is attributed to the studied institution having a leadership capable of providing an environment that supports teamwork, communication between individuals, and openness to the outside world to enhance learning at all levels within the institution. The leader's social intelligence plays a key role in facilitating individual creativity and knowledge sharing by motivating individuals to train, fostering a culture of collective learning among work teams, and providing the necessary resources for training and development within and outside the organization.

- The study results also revealed a significant impact of organizational change management on strategic leadership practices by developing the leader's skills and abilities in strategic planning and analyzing internal and external environmental factors (strengths and weaknesses, customer information, new competitors, leading organizations in the market, new products and services, advanced technology...), which contributes to creating clear perceptions about the organization's vision and future plans (training and development programs, performance improvement, sustainability, competition...).

5.2 Suggestions and Recommendations

Based on the results of the study, a number of suggestions and recommendations have been formulated, which can be summarized as follows:

- We recommend that leaders and owners of HODNA LAIT, in particular, and all economic institutions, in general, enhance their strategic thinking and change management efficiency by training leaders on a set of personal skills to make them more effective in performing their roles, such as strategic planning and environmental analysis skills.

- Emphasize the need to pay attention to strategic leadership practices by formulating visions and strategic directions and sharing important ideas with employees that could add value to the planning and organizational change process within the institution.

- Consider effective methods and strategies to overcome individual resistance to change. One of the most important is to present positive experiences of previous change projects that motivate them to accept the idea of change, while negative experiences will discourage them from being willing to embrace it.

- Work to establish the foundations of a stimulating organizational culture that motivates individuals and supports learning in business organizations so that they can build themselves as fully integrated learning organizations.
- Give ongoing learning processes more attention by redoubling efforts to improve the level of collective learning and develop the skills of learning teams.
- Work to encourage employees to experiment and learn from mistakes as a source of learning, which will increase their knowledge and ability to innovate.
- Enhance a culture of sharing and exchanging experiences and knowledge among employees as a means of facilitating the understanding and transfer of information between them.
- Finally, we considered presenting a proposed model for a learning organization in light of the existence of a significant role for strategic direction in industrial organizations. This is illustrated in the following figure:

Figure 09: A proposed model for building a learning organization

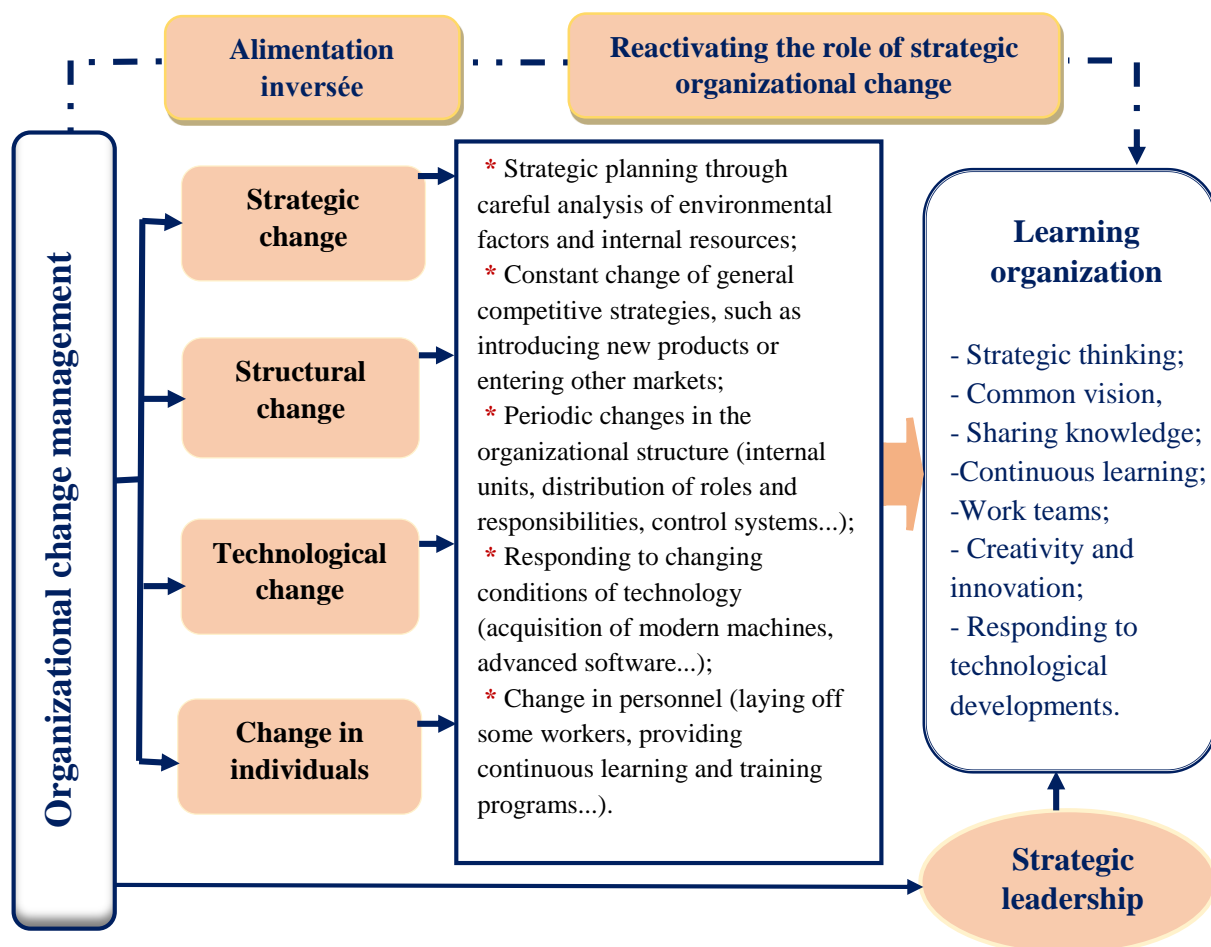

Source : Prepared by researchers

6. References

- Rabihi Mustafa Alian, (2015), *Change Management*, Tarig Al-Elm Library, Jordan.
- Boukrit, Nawi Al-Jami, (2020), *The Learning Organization and Organizational Change*, *Journal of Literature and Social Sciences*, Vol 21, No 02, pp305-318.
- Lakhdar, Ahmed, (2020), *the extent of the learning organization's readiness to adopt organizational change strategies - a case study of the Tax Directorate* *Forum Journal for Economic Studies and Research*, Vol 07, No 41, pp159-179.
- Thomas, Olajide Olubayo, (2014), *Change Management and its Effects on Organizational Performance of Nigerian Telecoms Industries: Empirical Insight from Airtel Nigeria*, *International Journal of Humanities Social Sciences and Education (IJHSSE)*, Vol 01, No 11, pp 170-179.
- Paton R.A, J McCalman, (2008), *Change management: A guide to effective implementation*, sage publication, london.
- Seng Peter, (1990) *the fifth discipline: the art and practice of the learning organization*, Currency Doubleday, USA.
- Gino D. Garvin & Edmondson E, (2008), *Is Yours a Learning Organization*, *Harvard Business Review*, Vol 86, No 03, pp108-132.
- Hill G. R, Charles W. & Jones R, (2006), *Strategic Management Theory: An Integrated Approach*, Houghton Mifflin.
- Normy Rafidap, Abdul R, (2018), *Impact of strategic leadership on organizational performance, strategic orientation and operational*, *Management Science Letters*, Vol 08, No 12, pp1387-1398.
- Anenih J.O.E, (2018), *Strategic Leadership in Public Sector*, *Doctor Dissertation of Philosophy Public Policy and Administration*, *College of Social and Behavioral Sciences*, *Walden University*, p15.

¹ Rabihi Mustafa Alian, *Change Management*, Tarig Al-Elm Library, Jordan, 2015, p12.

² Boukrit, Nawi Al-Jami, *The Learning Organization and Organizational Change*, *Journal of Literature and Social Sciences*, Vol 21, No 02, pp 305-318, 2020, p 306.

³ Lakhdar, Ahmed, *the extent of the learning organization's readiness to adopt organizational change strategies - a case study of the Tax Directorate -*, *Forum Journal for Economic Studies and Research*, Vol 07, No 41, pp159-179, 2020, p 161.

⁴ Rabihi Mustafa Alian, *op.cit*, p25.

⁵ Thomas, Olajide Olubayo, *Change Management and its Effects on Organizational Performance of Nigerian Telecoms Industries: Empirical Insight from Airtel Nigeria*, *International Journal of Humanities Social Sciences and Education (IJHSSE)*, Vol 01, No 11, pp 170-179, 2014, P172.

⁶ Paton R.A, J McCalman, *Change management: A guide to effective implementation*, sage publication, london, 2008, p36.

⁷ Seng Peter, *the fifth discipline: the art and practice of the learning organization*, Currency Doubleday, USA, 1990, p11.

⁸ Gino D. Garvin & Edmondson E, *Is Yours a Learning Organization*, *Harvard Business Review*, Vol 86, No 03, pp108-132, 2008, p112-113.

⁹ Hill G. R, Charles W. & Jones R, *Strategic Management Theory: An Integrated Approach*, Houghton Mifflin, 2006, p155.

¹⁰ Normy Rafidap, Abdul R, *Impact of strategic leadership on organizational performance, strategic orientation and operational*, *Management Science Letters*, Vol 08, No 12, pp1387-1398, 2018, p1388.

¹¹ Anenih J.O.E, *Strategic Leadership in Public Sector*, *Doctor Dissertation of Philosophy Public Policy and Administration*, College of Social and Behavioral Sciences, Walden University, 2018, p15.